

# INSTALLATION AND OPERATION INSTRUCTIONS

## Air Source Heat Pump Water Heater

NA33-160B

NA34-260B

NA35-160C

NA36-260C

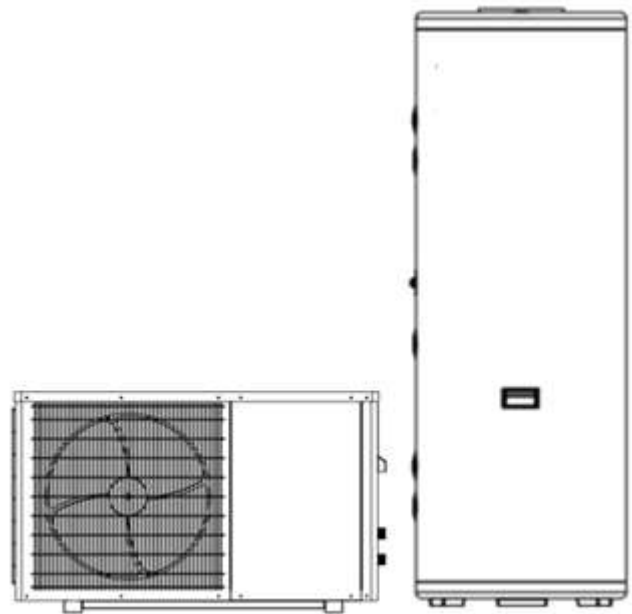

This instruction contains important information on the correct installation and operation of your heat pump water heater. Please read all the information before commencing installation and operation. Please retain it for future reference.

# Warning and Safety Instructions

---



## Note

Read this instruction carefully before using the appliance and retain it for future reference.

The information in this document is subject to change without prior notice.

This instruction includes a lot of safety information which follows the safety alert symbol, or word WARNING and CAUTION. Please pay particular attention to such safety information to avoid injury, or even death.

Please follow all safety precautions and instructions in this manual to avoid danger and to ensure the products optimum performance. NEVER operate the appliance unless it is professionally installed outdoors. Failure to do so can result in product malfunction, property damage, personal injury and/or death.

Should you have any problem in understanding this instruction, or have any question, please stop using the product and contact a qualified service technician to check.

---

## Keywords

Keywords	Meaning
WARNING	Means a dangerously hazardous situation and if failure to observe this information, it will result in property damage, serious personal injury or death.
CAUTION	Means a potentially hazardous situation and if failure to observe this information, it will result in product damage or minor injury.



## WARNING

- This appliance must be installed, commissioned, and serviced by an authorized technician following these instructions and local legislations and regulations.
- Improper installation may result in water leakage, electric shock or fire. Make sure that any power supply socket and plug are dry and connected tightly.
- Ensure that the appliance is earthed properly.
- DO NOT operate the unit with a wet hand as an electric shock may occur.
- All electric connections should comply with the regulations of the local power company, local electric utility and this instruction.
- Never use an incorrectly rated fuse, otherwise the unit may break down and cause an electrical fire.
- DO NOT insert fingers, rods or other objects into the air inlet or outlet of the heat pump unit. The fan is rotating at high speed, and may cause injury.
- The unit must be securely fixed, otherwise, noise and vibration may result.
- Make sure that there are no obstacles around the unit.
- This water heater could deliver hot water higher than 50°C. Make sure a temperature limited valve installed before the hot water delivered to every sanitary fixture.
- Water temperature over 50°C can cause severe burns or even death from scalds. Always check outlet water temperature by hand or by thermometer every time before use, such as when filling a bath or basin or entering a shower, to ensure it is suitable for the application and will not cause scald injury.



## WARNING

---

- This water heater is not intended for use by persons (including children) with reduced physical, sensory or mental capabilities, or lack of experience and knowledge, unless they have been given supervision or instruction concerning use of the appliance by a person responsible for their safety.
- Children should always be supervised to ensure that they do not play with this water heater. Whenever children are in the bathroom or near any source of hot water, ensure to supervise them and turn off the hot water fixtures tightly after use.
- DO NOT turn off the power supply except for service and maintenance purposes. A continuous power supply for water heating is necessary.
- **FOR CONTINUED SAFETY OF THIS APPLIANCE IT MUST BE INSTALLED, OPERATED AND MAINTAINED IN ACCORDANCE WITH THE MANUFACTURER'S INSTRUCTIONS.**
- **THIS APPLIANCE MAY DELIVER WATER AT HIGH TEMPERATURE. REFER TO THE PLUMBING CODE OF AUSTRALIA (PCA), LOCAL REQUIREMENTS AND INSTALLATION INSTRUCTIONS TO DETERMINE IF ADDITIONAL DELIVERY TEMPERATURE CONTROL IS REQUIRED.**
- **IF THE HOT WATER SYSTEM IS NOT USED FOR TWO WEEKS OR MORE, A QUANTITY OF HIGHLY FLAMMABLE HYDROGEN GAS MAY ACCUMULATE IN THE WATER HEATER. TO DISSIPATE THIS GAS SAFELY, IT IS RECOMMENDED THAT A HOT TAP BE TURNED ON FOR SEVERAL MINUTES OR UNTIL DISCHARGE OF GAS CEASES. USE A SINK, BASIN, OR BATH OUTLET, BUT NOT A DISHWASHER, CLOTHES WASHER, OR OTHER APPLIANCE. DURING THIS PROCEDURE, THERE MUST BE NO SMOKING, OPEN FLAME, OR ANY ELECTRICAL APPLIANCE OPERATING NEARBY. IF HYDROGEN IS DISCHARGED THROUGH THE TAP, IT WILL PROBABLY MAKE AN UNUSUAL SOUND AS WITH AIR ESCAPING.**



### Note

It is NECESSARY for installation to conform with the installation instructions, Plumbing Code of Australia (PCA), AS/NZS 3500.4, AS/NZS 3000 and all applicable local regulations and requirements.

---



## WARNING

- Hose-set is not to be used.
- DANGER: The operation of the thermal cut-out indicates a possibly dangerous situation. Do not reset the thermal cut-out until the water heater has been serviced by a qualified person.
- DANGER: Failure to operate the relief valve easing gear at least once every six months may result in the water heater exploding. Continuous leakage of water from the valve may indicate a problem with the water heater.
- If the water supply pressure exceeds the rated pressure, a pressure reducing valve is to be fitted in the installation.
- Before leaving the unit unused for a long time, please complete the following items:
  - Open the pipe orifice and drain water from water tank.
  - Further advice. Arrange drainpipes to ensure efficient drainage. Improper drainage can cause water damage to surrounding areas such as buildings, infrastructure etc.

Do not use means to accelerate the defrosting process or to Clean, Other than those recommended by the manufacturer.

The appliance shall be stored in a room without continuously operating ignition sources (For example: open flames, an Operating gas appliance or an operating electric heater.)

Do not pierce or burn.

Be aware that refrigerants may not contain an odour.

NOTE The manufacturer may provide other suitable examples or may provide Additional information about the refrigerant odour.



## INFORMATION SERVICING

### 1) Checks to the area

Prior to beginning work on systems containing flammable refrigerants, safety checks are necessary to ensure that the risk of ignition is minimized. For repair to the refrigerating system, the following precautions shall be complied with prior to conducting work on the system.

### 2) Work procedure

Works shall be undertaken under a controlled procedure so as to minimize the risk of a flammable gas or vapour being present while the work is being performed.

### 3) General work area

All maintenance staff and others working in the local area shall be instructed on the nature of work being carried out. Work in confined spaces shall be avoided. The area around the work space shall be sectioned off. Ensure that the conditions within the area have been made safe by control of flammable material.

### 4) Checking for presence of refrigerant

The area shall be checked with an appropriate refrigerant detector prior to and during work, to ensure the technician is aware of potentially flammable atmospheres. Ensure that the leak detection equipment being used is suitable for use with flammable refrigerants, i.e. no sparking, adequately sealed or intrinsically safe.

### 5) Presence of fire extinguisher

If any hot work is to be conducted on the refrigeration equipment or any associated parts, appropriate fire extinguishing equipment shall be available to hand. Have a dry powder or CO2 fire extinguisher adjacent to the charging area.

### 6) No ignition sources

No person carrying out work in relation to a refrigeration system which involves exposing any pipe work

that contains or has contained flammable refrigerant shall use any sources of ignition in such a manner that it may lead to the risk of fire or explosion.

All possible ignition sources, including cigarette smoking, should be kept sufficiently far away from the site of installation, repairing, removing and disposal, during which flammable refrigerant can possibly be released to the surrounding space. Prior to work taking place, the area around the equipment is to be surveyed to make sure that there are no flammable hazards or ignition risks. NO SMOKING signs shall be displayed.

#### 7) Ventilated area

Ensure that the area is in the open or that it is adequately ventilated before breaking into the system or conducting any hot work.

A degree of ventilation shall continue during the period that the work is carried out. The ventilation should safely disperse any released refrigerant and preferably expel it externally into the atmosphere.

#### 8) Checks to the refrigeration equipment

Where electrical components are being changed, they shall be fit for the purpose and to the correct specification. At all times the manufacturer's maintenance and service guidelines shall be followed. If in doubt consult the manufacturer's technical department for assistance. The following checks shall be applied to installations using flammable refrigerants.

#### 9) Checks to electrical devices

Repair and maintenance to electrical components shall include initial safety checks and component inspection procedures. If a fault exists that could compromise safety, then no electrical supply shall be connected to the circuit until it is satisfactorily dealt with. If the fault cannot be corrected immediately but it is necessary to continue operation, an adequate temporary solution shall be used. This shall be reported to the owner of the equipment so all parties are advised.

Initial safety checks shall include:

The charge size is in accordance with the room size within which the refrigerant containing parts are installed.

The ventilation machinery and outlets are operating adequately and are not obstructed.

If an indirect refrigerating circuit is being used, the secondary circuits shall be checked for the presence of refrigerant; marking to the equipment continues to be visible and legible.

Marking and signs that are illegible shall be corrected.

Refrigeration pipe or components are installed in a position where they are unlikely to be exposed to any substance which may corrode refrigerant containing components, unless the components are constructed of materials which are inherently resistant to corrosion or are suitably protected against being corroded.

That capacitors are discharged: this shall be done in a safe manner to avoid possibility of sparking.

That there is no live electrical component and wiring are exposed while charging, recovering or purging the system.

That there is continuity of earth bonding.

#### 10) Repairs to sealed components

Ensure that apparatus is mounted securely.

Ensure that seals or sealing materials have not degraded such that they no longer serve the purpose of preventing the ingress of flammable gas to atmosphere. Replacement parts shall be in accordance with the manufacturer's specifications.

#### 11) Repair to intrinsically safe components

Do not apply any permanent inductive or capacitance loads to the circuit without ensuring that this will not exceed the

permissible voltage and current permitted for the equipment in use. Intrinsically safe components are the only types that can be worked on while live in the presence of a flammable atmosphere. The test

apparatus shall be at the correct rating. Replace components only with parts specified by the manufacturer. Other parts may result in the ignition of refrigerant in the atmosphere from a leak.

#### 12) Cabling

Check that cabling will not be subject to wear, corrosion, excessive pressure, vibration, sharp edges or any other adverse environmental effects. The check shall also take into account the effects of aging or continual vibration from sources such as compressors or fans.

#### 13) Detection of flammable refrigerants

Under no circumstances shall potential sources of ignition be used in the searching for or detection of refrigerant leaks.

A halide torch (or any other detector using a naked flame) shall not be used.

#### 14) Leak detection methods

The following leak detection methods are deemed acceptable for systems containing flammable refrigerants. Electronic leak detectors shall be used to detect flammable refrigerants, but the sensitivity may not be adequate, or may need re-calibration. (Detection equipment shall be calibrated in a refrigerant-free area.) Ensure that the detector is not a potential source of ignition and is suitable for the refrigerant. Leak detection equipment shall be set at a percentage of the LFL of the refrigerant and shall be calibrated to the refrigerant employed and the appropriate percentage of gas

(25% maximum) is confirmed. Leak detection fluids are suitable for use with most refrigerants but the use of detergents containing chlorine shall be avoided as the chlorine may react with the refrigerant and corrode the copper pipe-work. If a leak is suspected, all naked flames shall be removed or extinguished. If a leakage of refrigerant is found which requires brazing, all of the refrigerant shall be recovered from the system, or isolated (by means of shut off valves) in a part of the system remote from the leak. Oxygen free nitrogen (OFN) shall then be purged through the system both before and during the brazing process.

#### 15) Removal and evacuation

When breaking into the refrigerant circuit to make repairs or for any other purpose conventional procedures shall be used, however, it is important that best practice is followed since flammability is a consideration. The following procedure shall be adhered to:

Remove refrigerant;

Purge the circuit with inert gas;

Evacuate;

Purge again with inert gas;

Open the circuit by cutting or brazing.

The use of silicon sealant may inhibit the effectiveness of some types of leak detection equipment. Intrinsically safe components do not have to be isolated prior to working on them.

#### NOTE

The refrigerant charge shall be recovered into the correct recovery cylinders. The system shall be flushed with OFN to render the unit safe. This process may need to be repeated several times.

Compressed air or oxygen shall not be used for this task.

Flushing shall be achieved by breaking the vacuum in the system with OFN and continuing to fill until the working pressure is achieved, then venting to atmosphere, and finally pulling down to a vacuum. This process shall be repeated until no refrigerant is within the system.

When the final OFN charge is used, the system shall be vented down to atmospheric pressure to enable work to take place.

This operation is absolutely vital if brazing operations on the pipe-work are to take place.

Ensure that the outlet for the vacuum pump is not closed to any ignition sources and there is ventilation available.

#### 16) Charging procedures

In addition to conventional charging procedures, the following requirements shall be followed:  
Ensure that contamination of different refrigerants does not occur when using charging equipment.  
Hoses or lines shall be as short as possible to minimize the amount of refrigerant contained in them.  
Cylinders shall be kept upright.  
Ensure that the refrigeration system is earthed prior to charging the system with refrigerant.  
Label the system when charging is complete (if not already).  
Extreme care shall be taken not to overfill the refrigeration system.  
Prior to recharging the system it shall be pressure tested with OFN. The system shall be leak tested on completion of charging but prior to commissioning. A follow up leak test shall be carried out prior to leaving the site.

#### 17) Decommissioning

Before carrying out this procedure, it is essential that the technician is completely familiar with the equipment and all its detail.

It is recommended good practice that all refrigerants are recovered safely. Prior to the task being carried out, an oil and refrigerant sample shall be taken.

In case analysis is required prior to re-use of reclaimed refrigerant. It is essential that electrical power is available before the task is commenced.

a) Become familiar with the equipment and its operation.

b) Isolate system electrically

c) Before attempting the procedure ensure that:

Mechanical handling equipment is available, if required, for handling refrigerant cylinders.

All personal protective equipment is available and being used correctly.

The recovery process is supervised at all times by a competent person.

Recovery equipment and cylinders conform to the appropriate standards.

d) Pump down refrigerant system, if possible.

e) If a vacuum is not possible, make a manifold so that refrigerant can be removed from various parts of the system.

f) Make sure that cylinder is situated on the scales before recovery takes place.

g) Start the recovery machine and operate in accordance with manufacturer's instructions.

h) Do not overfill cylinders. (No more than 80% volume liquid charge).

i) Do not exceed the maximum working pressure of the cylinder, even temporarily.

j) When the cylinders have been filled correctly and the process completed, make sure that the cylinders and the equipment are removed from site promptly and all isolation valves on the equipment are closed off.

k) Recovered refrigerant shall not be charged into another refrigeration system unless it has been cleaned and checked.

#### 18) Labelling

Equipment shall be labelled stating that it has been de-commissioned and emptied of refrigerant. The label shall be dated and signed. Ensure that there are labels on the equipment stating the equipment contains flammable refrigerant.

#### 19) Recovery

When removing refrigerant from a system, either for service or decommissioning, it is recommended good practice that all refrigerants are removed safely.

When transferring refrigerant into cylinders, ensure that only appropriate refrigerant recovery cylinders are employed.

Ensure that the correct numbers of cylinders for holding the total system charge are available. All cylinders to be used are designated for the recovered refrigerant and labelled for that refrigerant (i.e special cylinders for the recovery of refrigerant). Cylinders shall be complete with pressure relief valve

and associated shut-off valves in good working order.

Empty recovery cylinders are evacuated and, if possible, cooled before recovery occurs.

The recovery equipment shall be in good working order with a set of instructions concerning the equipment that is at hand and shall be suitable for the recovery of flammable refrigerants. In addition, a set of calibrated weighing scales shall be available and in good working order.

Hoses shall be complete with leak-free disconnect couplings and in good condition. Before using the recovery machine, check that it is in satisfactory working order, has been properly maintained and that any associated electrical components are sealed to prevent ignition in the event of a refrigerant release. Consult manufacturer if in doubt.

The recovered refrigerant shall be returned to the refrigerant supplier in the correct recovery cylinder, and the relevant

Waste Transfer Note arranged. Do not mix refrigerants in recovery units and especially not in cylinders.

If compressors or compressor oils are to be removed, ensure that they have been evacuated to an acceptable level to make certain that flammable refrigerant does not remain within the lubricant. The evacuation process shall be carried out prior to returning the compressor to the suppliers. Only electric heating to the compressor body shall be employed to accelerate this process. When oil is drained from a system, it shall be carried out safely.

20) Transportation, marking and storage for units

Transport of equipment containing flammable refrigerants Compliance with the transport regulations.

Marking of equipment using signs Compliance with local regulations.

Disposal of equipment using flammable refrigerants Compliance with national regulations.

Storage of equipment/appliances.

The storage of equipment should be in accordance with the manufacturer's instructions.

Storage of packed (unsold) equipment.

Storage package protection should be constructed such that mechanical damage to the equipment inside the package will not cause a leak of the refrigerant charge.

The maximum number of pieces of equipment permitted to be stored together will be determined by local regulations.



# Contents

Warning and Safety Instructions.....	2
1. Products Information.....	10
2: Installation.....	15
3. Controller Instructions.....	21
4. Repair and Maintenance .....	24
5. Trouble shooting.....	26

# 1. Products Information

## 1.1 Working Principles of Air Source Heat Pump Water Heater

The compressor draws refrigerant vapor which is low temperature and low pressure from evaporator and significantly increases the pressure and temperature of vapor. Then the refrigerant will exchange heat with water in the water tank and become liquid state. The water keeps absorbing the heat and the temperature is rising. The high pressure liquid will go through the throttling device to significantly reduce pressure and temperature. Finally the fan draws air through the evaporator and the cold liquid refrigerant absorbs heat from air to become vapor again. The refrigerant will continuously run the above way so as to heat water.

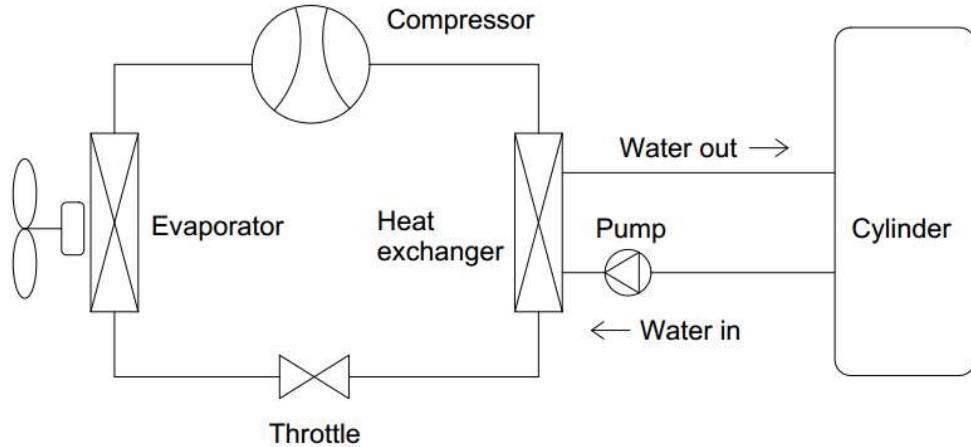

Fig.1 working principles of air source heat pump water heater



### Note

All pictures in this manual are for explanation purpose only. They may differ from actual unit.

## 1.2 System Schematics Dimensions(millimetres)

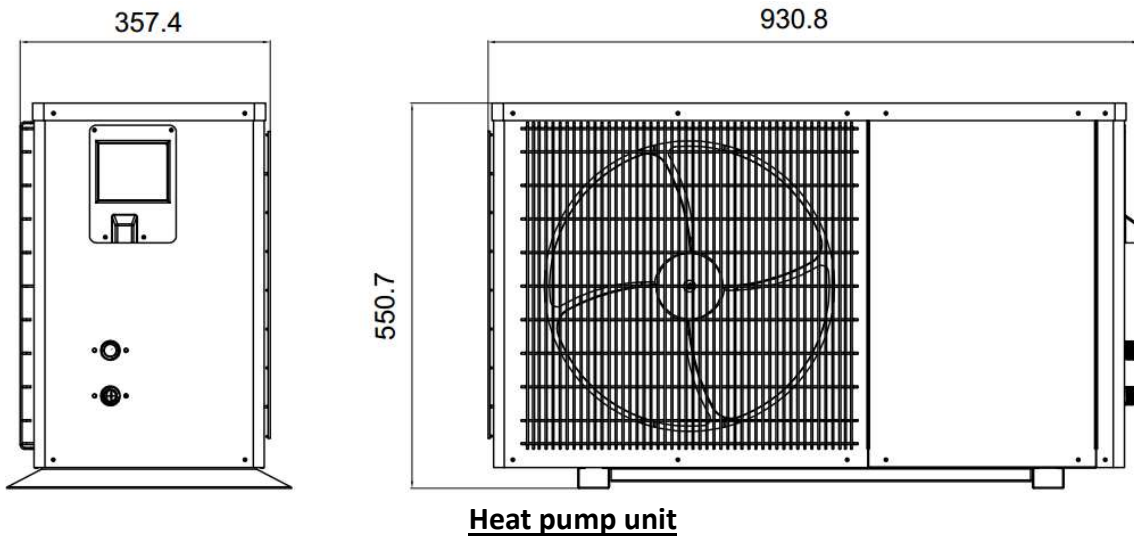

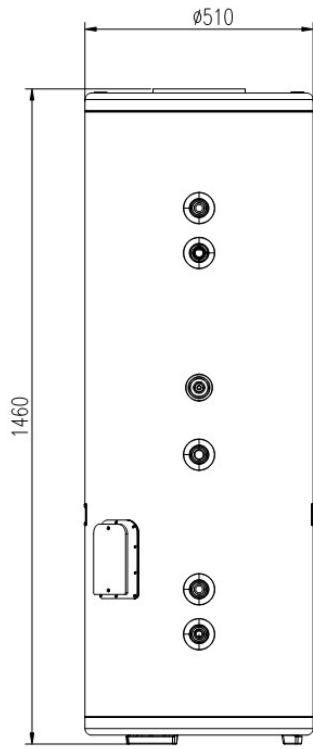

**160L cylinder**

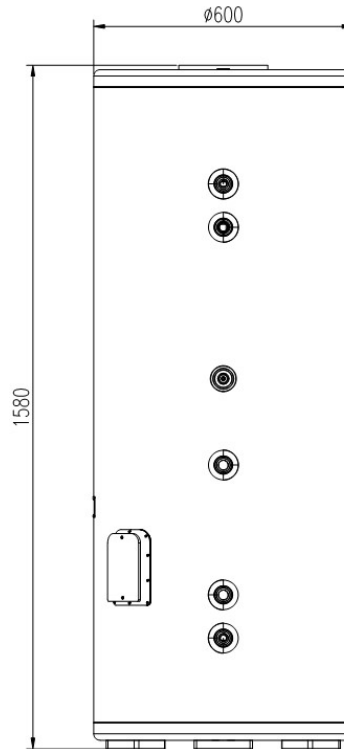

**260L cylinder**

### 1.3 System parts

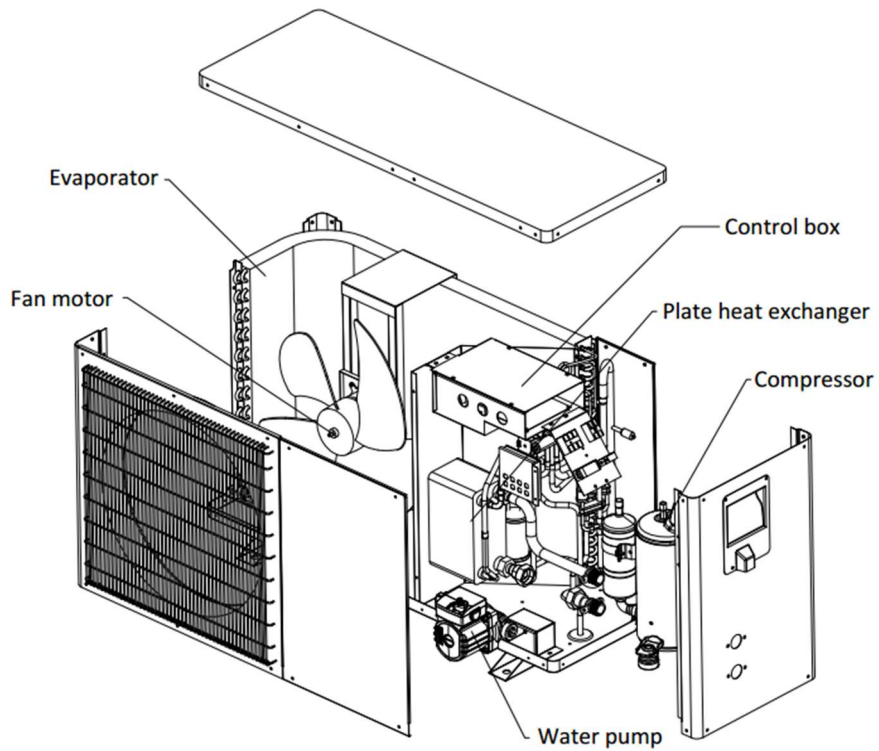

**Heat pump unit**

## 1.4 Specifications

Model	NA33-160B NA35-160C	NA34-260B NA36-260C
<b>Heat pump unit</b>		
Power supply (V/Hz)	220-240V ~/50Hz	220-240V ~/50Hz
Heating capacity(W)	3500	3500
Rated power input(W)	865	865
Rated current (A)	3.75	3.75
Max input power (W)	1250	1250
Max input current (A)	5.80	5.80
Water yield (L/h)	70	70
Ambient Temp. range(°C)	-7~43	-7~43
Standard outlet Temp.(°C)	55	55
Refrigerant type (g)	R32(770)	R32(770)
Noise level (dB(A))	51	51
Net size(mm)	931*407*551	931*407*551
Packing size (mm)	980*415*700	980*415*700
N.W (Kg)	50.0	50.0
G.W (Kg)	60.0	60.0
<b>Cylinder</b>		
Storage volume(L)	160	260
Inner tank	Enameled water tank	Enameled water tank
Max tank pressure (Mpa)	0.8	0.8
Water inlet/outlet pipe (mm)	DN20	DN20
Drainage pipe (mm)	DN20	DN20
Magnesium rod joint (mm)	M33	M33
Net size(mm)	φ510x1460	φ600x1580
Packing size (mm)	580*580*1540	670*670*1680
N.W (Kg)	51.0	77.0
G.W (Kg)	58.0	85.0
Electric heater(w)	2000	2000
Water proof class	IPX4	IPX4

1. Condition: ambient air 19°C DB/15°C WB, incoming/final water temperature 15°C /55°C.
2. Electric heater is only applied on NA33-160B and NA34-260B.
3. Data subject to change without prior notice.



### Note

All data in this manual are subject to change without prior notice.

## 1.5 Electrical diagram

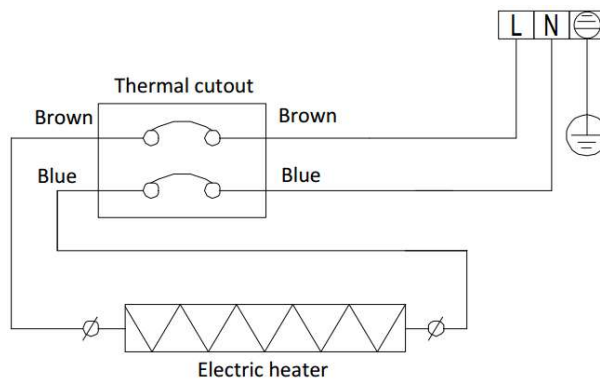
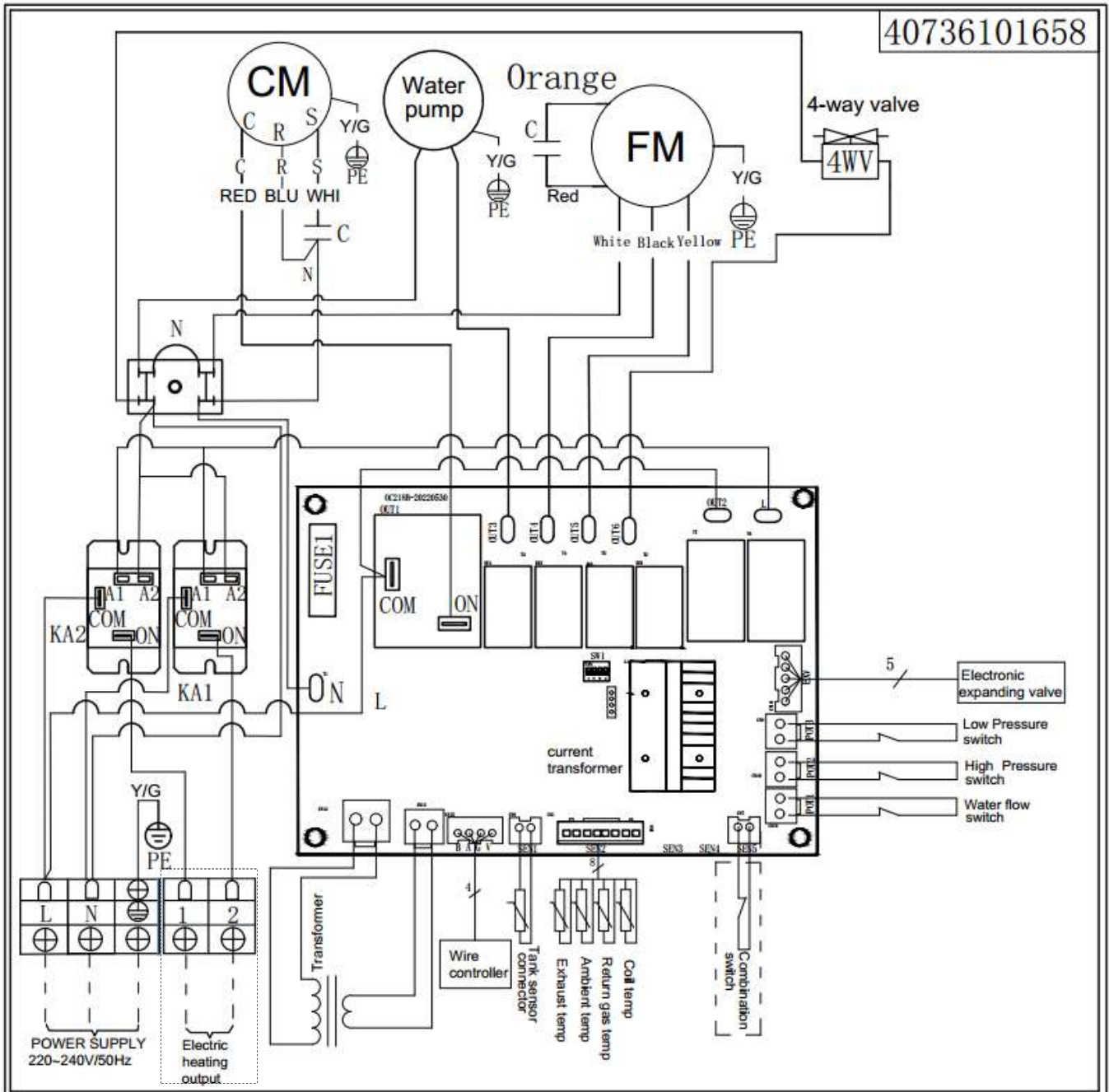

### Note

The electric heater is optional.

## 1.6 Packing list

When unpacking ensures the following items are included:

Heat pump unit		
No	Item	Qty.
1	Heat pump unit	1
2	Installation and Operation Instructions	1
3	Power cable	1
4	Drainage tube	1
5	Drainage mouth	1
6	Rubber pad	4
7	Wired controller	1
8	Water tank temperature sensor	1

Cylinder		
No	Item	Qty.
1	Water tank	1
2	TP valve	1
3	Cable for backup heater	1
4	Waterproof box for controller installation	1



### Note

If the accessories list updates as products improve, there will be no further notice. Please refer to the actual packing list.

---

## 2: Installation

### 2.1. Appliance layout

#### Heat pump unit

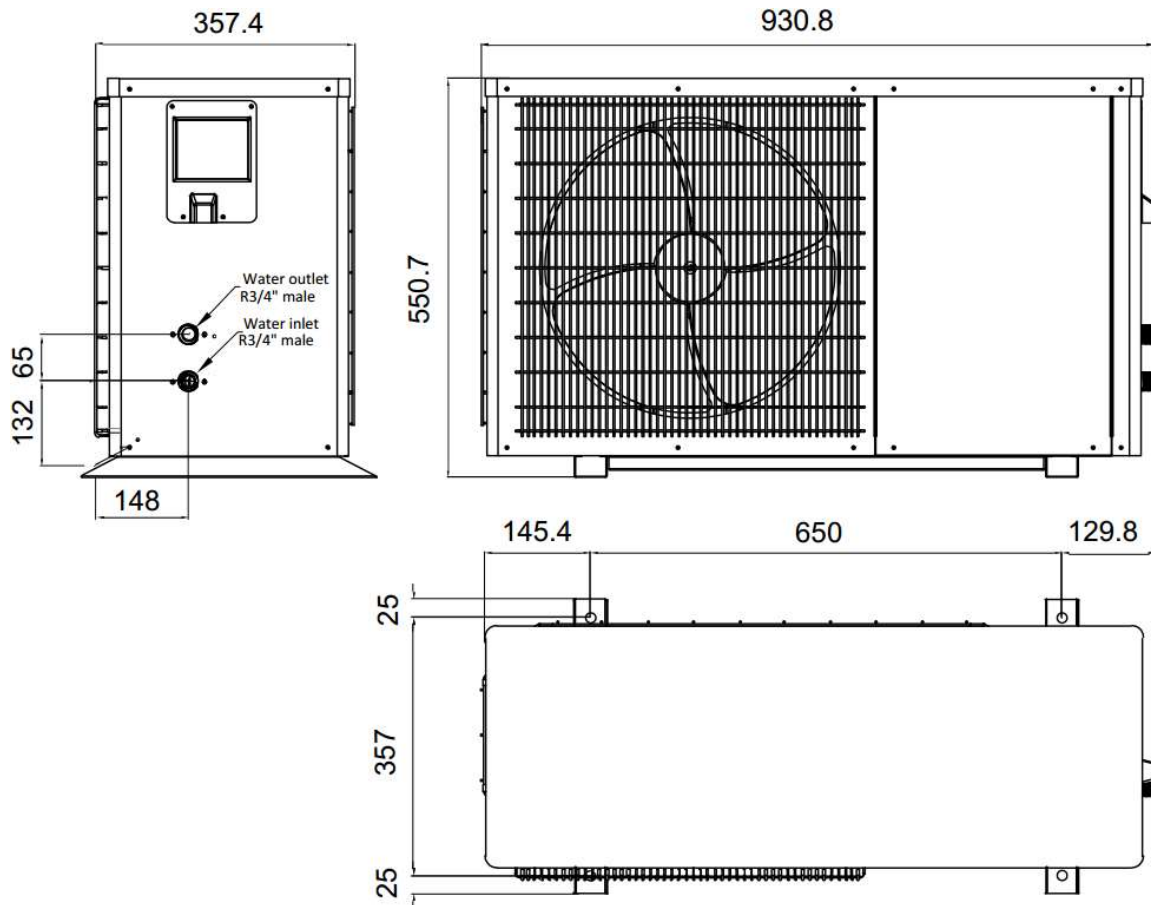

#### Water cylinder

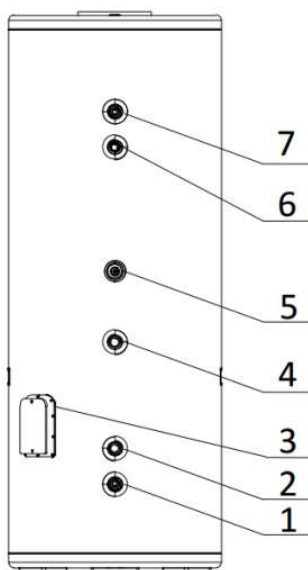

1. Cold water feed, G3/4 female
2. Circulation water return, G3/4 female
3. Electric heater(optional)
4. Circulation water supply G3/4 female
5. Water cylinder temperature sensor
6. TP valve,G1/2 female
7. Hot water supply, G3/4 female

### 2.2. Appliance Moving

1. This appliance is quite heavy so that it requires two or more people to move and install, or it may

cause in personal injury or other accidents.

2. Transport the appliance as its delivery condition, do not disassemble it.
3. In order to avoid scratches and deformation on the surface, please add protection board over the surface of the appliance where may contact hard objects directly.
4. DO NOT touch the fan with your hand or any other objects.
5. DO NOT transfer the appliance with inclination over 45°. DO NOT lay down the appliance on the floor.

## 2.3. Installation Location

### 2.3.1 Installation location for heat pump unit:

- 1) Avoid direct sunlight.
- 2) MUST keep away from heat sources, steam sources, places with flammable gas leakage and smoke.
- 3) Select a place that is not easily exposed to rain and has good ventilation.
- 4) It can provide enough space for installation and maintenance.
- 5) The installation foundation shall be solid and reliable, otherwise the running noise and vibration will be increased.
- 6) Ensure that the installation space is not less than the requirements in the following figure.
- 7) Ensure the air outlet is free. Obstacles will affect the performance.
- 8) The outdoor unit shall not occupy the public sidewalk. The distance from the bottom of the installation frame of the air source heat pump water heater installed along the buildings on both sides of the road to the ground shall be more than 2.5 m.
- 9) The appliance should be installed outdoors. It is not allowed to install the appliance in humid places.
- 10) Select a place where water pipes and electric power can be easily connected and serviced.

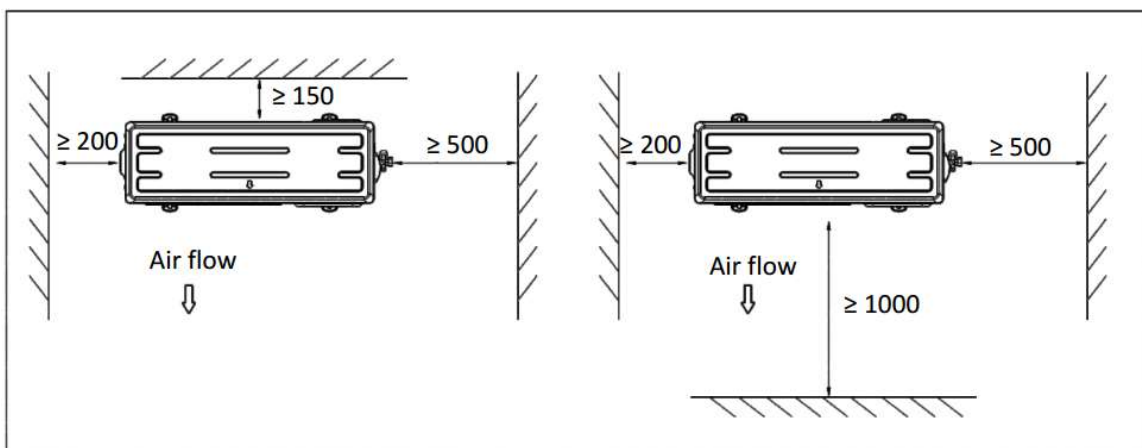

### 2.3.2 Installation location for water cylinder:

- 1) It can provide enough space for installation and maintenance.
- 2) Select a flat bearing surface that can support the weight of the tank (when filled with water) and can be fixed in the vertical direction.
- 3) It is convenient to install and connect water pipes and electrical connections.
- 4) The water discharged from TP valve operation can be discharged smoothly.
- 5) When the safety valve is working, the water discharged from the safety valve will not splash onto the wooden floor and furniture.



CAUTION

1. Avoid locations with high salt levels, corrosive gas, flammable items, or mineral oils.
2. Avoid locations with serious power supply voltage fluctuation.
3. Avoid places with strong electromagnetic waves.
4. Avoid unstable locations such as cars, mobile homes and cabins.



## 2.4. Installation Requirements

1. The appliance **MUST** be placed vertical and stable. The water pipes, water filter, and one-way TP valve should be installed in accordance with the national standards.
2. Water filling: Turn on the water outlet and water inlet valve. When there is water comes out of the outlet means the water tank is full. You can switch on the heater after that.
3. The water quality should meet the following standards: Hardness  $\leq 200\text{mg/L}$ ,  $\text{Ca} \leq 200\text{mg}$ , Chloride ions  $\leq 50\text{mg/L}$ , PH value  $6.5 \sim 8.5$ , conductivity  $< 200\mu\text{V/cm}$  ( $25^\circ\text{C}$ ), total dissolved solids  $< 600\text{mg/L}$  or ppm, Magnesium  $< 10\text{mg/L}$  or ppm, Sodium  $< 150\text{mg/L}$  or ppm, Iron  $< 1\text{mg/L}$  or ppm, dissolved (free)  $\text{CO}_2 < 25\text{mg/L}$  or ppm. And the inner water tank should be cleaned regularly.
4. If the sediment and dirt in the water tank are removed regularly, the operation efficiency will be improved. Method: close the power supply and water inlet valve, open the water outlet and water inlet, and the sewage and sediment will come out until the sewage is discharged.

## 2.5. Plumbing Connection

### 2.5.1 Typical Plumbing Connection Schematics

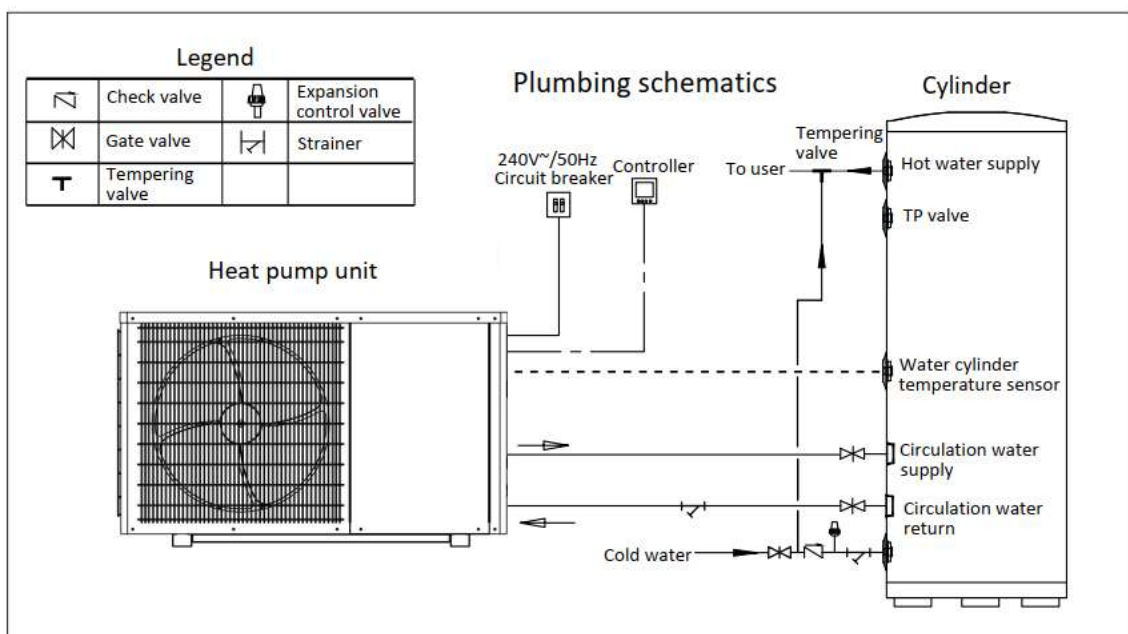

### Note

1. Installation of expansion control valve must follow local regulations.
2. For model with optional electric heater need to wiring from the heat pump unit to the cylinder.
3. Please refer to specification on Page 12 and 15 for connection size information. Pipes inner diameter between heat pump unit and cylinder should be no less than 20mm.



### CAUTION

1. DO NOT use iron pipes and smelly PVC pipes to install the appliance. The water pipeline system should adopt new pipes that can meet drinking water standards.
2. Install the water pipes, connectors and other parts according to above figure. If the installation environment is under  $0^\circ\text{C}$ , all pipes should be with insulation treatment.
3. Please keep the TP valve outlet clean and unblocked. Condensation pipe should be able to drain water smoothly, the route must be downward gradient without any bend upward.
4. Always follow the local regulations and plumbing standards.

## 2.5.2 Plumbing Connection Instructions

### (1) Installation requirements of water inlet pipes

The lifetime of pipes and pipe components cannot be shorter than the lifetime of the appliance, and they should be able to withstand high temperature of 85°C, so as to avoid damage.

### (2) Installation requirements of TP valve connection pipes

Make sure the water can flow out of the TP valve and the drainage outlet should be installed straight downwards. After finishing installation, please make sure that drainage hose connected to the TP valve's drainage outlet should be maintain downward and stay open to the frost-free environment.

(3) The pressure ranges of the water tank is 0.15MPa~0.8MPa. If the water inlet pressure is always lower than 0.15MPa and in order to get higher water flow to meet water consumption requirement, you need to add a booster pump at the water inlet so as to keep the water pressure no lower than 0.15MPa; if the water inlet pressure is always higher than 0.5MPa, you need to add a reducing valve of 0.5MPa at water inlet pipe so as to make sure the safety use of the tank.

(4) Refer to the above plumbing connection schematics to make the plumbing connection. After plumbing pipes to the tank and heat pump unit is installed correctly, following steps must be taken to ensure the tank is fully filled with water and all air is removed from the water system. Incorrect removal of air may cause the water the unit fault.

- Push the handle up of the TP valve to open and fill the tank with water.
- Confirm that the water flow out from the valve and then close the handle.
- Open all hot water taps to remove air in the water system.
- After no air is expelled and only water comes out from all hot water taps, then close the hot water taps.

## 2.6. Electrical Connections



### WARNING

1. All electrical connections and wiring must be installed, maintained and removed by authorized persons in accordance with AS/NZS 3000, and all other relevant local regulations.
2. The power supply to the heat pump module MUST NOT be activated until the system is fully filled with water.
3. If the supply cord is damaged, it must be replaced by the manufacturer, its service agent or similarly qualified persons in order to avoid a hazard.



### CAUTION

1. The Heat Pump is fitted with a power cord. It MUST have the supply terminals connected to an independent, fused, AC 240V 50 Hz power supply with an isolating switch installed at the switch board, which shall effectively isolate all active supply conductors from the circuit.
2. A Residual Current Circuit Breaker is recommended for the power supply to this appliance (this may be a mandatory requirements in some states or jurisdictions).

### Wiring terminal and connections on site

The main power supply connected to the heat pump unit. The tank sensor and wire controller must be connected on site between the heat pump unit and the cylinder. For model with optional electric heater, the electric heater need to be wiring from the heat pump unit to the cylinder. Refer to below picture for the wiring.

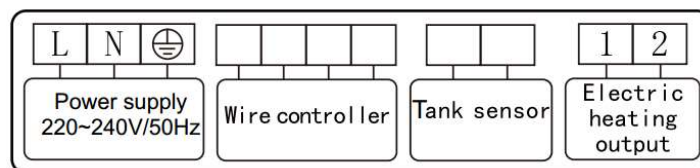

1. This appliance should use specified power cord, which should be required as the below table. The voltage of power should also be suitable with the rated voltage requirement.
2. The power supply circuit should have ground wire, which should be connected with outside ground effectively.
3. Wiring connection must be done by professional technical person and operate strictly according to the electrical diagram.
4. Set up earth leakage protection according to the relevant national electrical equipment standards.
5. Double check the electrical circuit before connecting to the power supply.
6. Do not disconnect or disassemble the ground wire, or use broken cables and switches under any circumstances. If you find out any breakage, the power cord must be replaced as soon as possible.
7. The interconnection cord of tank sensor and wire controller must be securely fixed, its connectors shall be far away from metal enclosure, terminal block and any live parts.

### Power Specifications

Power supply	Power Cord Diameter (mm <sup>2</sup> )		Circuit Breaker (A)		Earth Leakage Protection
	Neutral Wire/Live Wire (Length≤30m)	Ground Wire	Capacity	Fuse	
220-240V AC~ 50Hz	≥2.5	≥2.5	20	15	30mA Below 0.1 sec

## **2.7. Commissioning the System**

### **(1) Before commissioning**

- The appliance should be installed and completed correctly.
- Piping and wiring should be correct.
- Power supply voltage should match with the rated voltage.
- Drainage should work smoothly.
- The insulation should be complete.
- The ground wire should be properly connected.
- There should not be any obstacles at the air inlet and air outlet orifices.
- Make sure the water tank is fully filled with water.

### **(2) Operation with power**





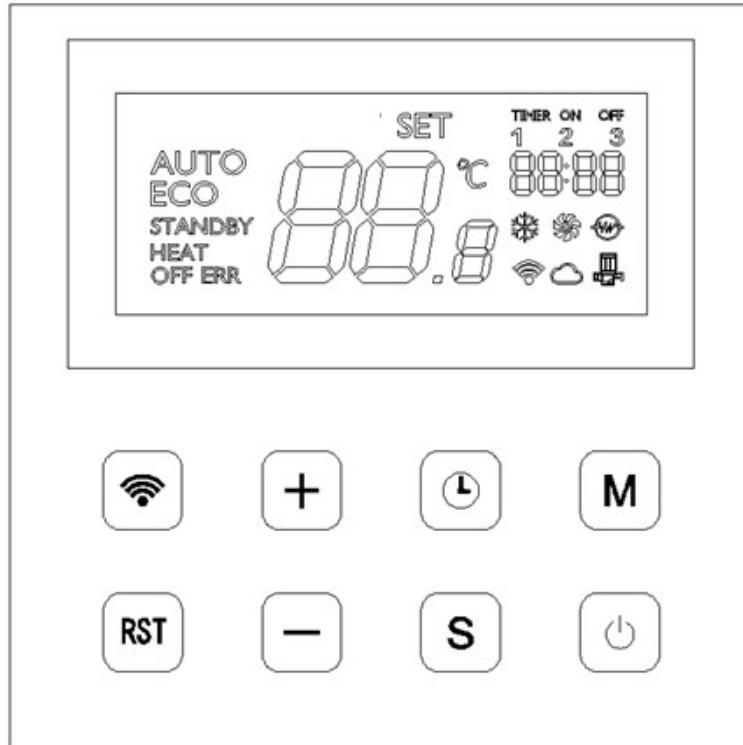

- Make sure all the control switches are normal as well as all function buttons are good.
- Observe if hot water system works properly and the temperature of outlet water is normal or not.
- When the TP valve is working, please check if it can drain out water successfully.
- There is no any abnormal vibration or sound during the appliance operation.

# 3. Controller Instructions









## ■ Displays and Buttons



### 3.1 Display Icon Illustration

AUTO	Auto mode icon	Light up means the appliance operating in AUTO mode
ECO	Eco mode icon	Light up means the appliance operating in ECO mode
STANDBY	Standby mode icon	Light up means the appliance is in standby mode
HEAT	Heating mode icon	Light up means the appliance operating in heating mode
OFF	Off mode icon	Light up means the appliance is off
ERR	Error mode icon	Light up means the appliance is malfunction
SET	Setting icon	Light up means you are setting parameters
TIMER	Timer icon	Light up means timer on/off is activated
	Fan icon	Light up means the fan is running
	Defrost icon	Light up means the heat pump is defrosting
	Electric heater icon	Light up means the electric heater is running
	Wi-Fi icon	Light up means Wi-Fi is connected (Reserved)
	Water pump icon	Light up means the water pump is running
	Remote control	Optional

## 1. Operation Button Illustration

	Wifi button	To connect with Wifi ( Reserved)
	Reset button	To return to default setting from factory
	Add button	To add setting
	Reduce button	To reduce setting
	Clock button	To set clock or timer
	Set button	To set parameters
	Mode button	To change mode
	On/off button	To start/stop the appliance

### ■ Operation Instruction

#### 1. Switch on/off heat pump



From home page, press  button to light up the controller.



From home page, press  button for 3s to switch on/off heat pump.

When heat pump is running, temperature area displays actual tank water temperature.

When heat pump is standby, temperature area displays actual tank water temperature.

#### 2. Set desired water temperature

From home page, press  or  to enter water temperature setting page.

Then press  or  to change desired water temperature setting.

Press  to save setting. It will save setting and return to home page if no action for 5s.







#### 3. Set operation mode

When heat pump is running, from home page press  button to set working mode.

There are two modes which are **AUTO, ECO**.

When running in **ECO** mode, the appliance running according to scheduled **TIMER**.

#### 4. Set timer on/off



When the heat pump is running, from home page press  button for 3S to enter timer setting page. **TIMER 1 ON** and hour setting starts to flash, press  or  button to set the hour. When finish press  switch to **TIMER 1** minute setting, press  or  button to set the minute time.





When finish press  to set **TIMER 1 OFF**, the same as above.

Continue to press  to set **TIMER 2** and **TIMER 3**.

After complete the timer setting, press the timer button again to confirm and return to home page.

## 5. Set clock

When heat pump is running, from home page press  button to enter clock setting page and hour setting starts to flash, press  or  button to set the hour time.

Press  button to switch to minute setting page and press  or  button to set the minute time. Then press  to save and return to home page.

## 6. Return to factory default setting

Press  for 4S the controller display dEF, and then press  to save.

## 7. Electric booster (for models with electric element)

When the set outlet temperature could not be reached within 8h by heat pump, the electric booster will be triggered to heat automatically. When ambient temperature is below  $-7^{\circ}\text{C}$ , the electric element will be triggered to heat automatically. When error occurs on heat pump heating mode, the electric element will be triggered to heat automatically. If user prefers a fast heating, they could press the  button for 4s to trigger the electric element.

## 4. Repair and Maintenance

When using the air source heat pump water heater, please check the operation condition regularly. If it can provide long-term and effective maintenance, the appliance operation reliability and service span will be improved.

1. Clean the water filter regularly and make sure that the water within the system is clean, avoiding damages due to the blocking of water filter.
2. All safety protection devices have been set correctly and completely in the factory, so please do not adjust on your own.
3. The appliance should be kept in clean and dry places with good ventilation so as to achieve good heat exchange. Please clean the filter regularly according to different extent of the environmental pollution.
4. To ensure the long-term work efficiency, it is recommended to drain the inner water out and clean one time every six months, remove accumulative sediment during the operation. Detail operation is as below:
  - 1) Turn off the electricity supply to the water heater
  - 2) Turn off the isolating valve at the cold water supply pipe to the water heater.
  - 3) Turn off all the hot water taps.
  - 4) Gently operate the easing lever on the PTR valve to release the pressure in the water heater.
  - 5) Disconnect the cold water inlet union and attach a drain hose to the water heater.
  - 6) Gently operate the easing lever on the PTR valve to let air into the water heater and allow water to drain through the hose.



### WARNING

- 
- Draining must be carried out by a qualified / authorised person.
  - Water may be very hot during draining, please be careful.
  - Before proceeding the draining, the electricity supply to the water heater must be shut off.
5. Please check regularly whether the power supply and the wiring of electrical system of the product are firm or not, whether the electrical components have any abnormal phenomenon or not. If there is any problem, please contact the authorized technician to replace and repair the appliance.
  6. Please check whether the TP valve of water system is working properly or not, so as not to affect the heating capacity and the reliability of the operation.
  7. If you shut down the appliance for a long time, please remove the water in pipes system and the tank, then cut off the power and put a protection cover. Before re-operating the appliance, please conduct a comprehensive examination of the system first, fill with water and then restart the appliance.
  8. Each appliance is equipped with an anode rod to protect the water tank from corrosion, but the anode rod will also be corroded slowly. The corrosion rate depends on the local water quality. We recommend that you check the anode rod once a year and change a new one if the anode rod runs out. For location with hard water please check the anode every 6 months, and replace the anode if needed. Please contact the dealer or special technical center about detailed information.
  9. To the regions where temperature is below 0°C, please be sure to insulate the water inlet and outlet pipes. If necessary, install pipe heating device to avoid pipes freezing.
  10. When the appliance is breakdown and the user cannot solve the problem, please contact the local service center or dealer to send servicemen to repair the appliance promptly.



Disposal: Do not dispose of electrical appliances as unsorted municipal waste. A separate collection facility should be used. Contact your local government to find out information about the collection system. If electrical appliances are disposed of in landfills or dump site, where hazardous substances can seep into groundwater and cause health problems question.



 WARNING

- Take care to avoid any splashing of water, as water discharged from the drain pipe will be hot.
- If water does not flow freely from the drain pipe when the lever is lifted, the water heater must be checked by an authorized person.

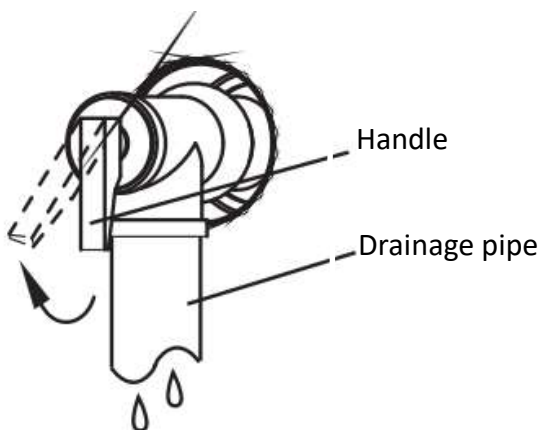

- Stand clear of the pressure and temperature valve (PTR) drain pipe outlet.
- Open the PTR valve for approximately 10 seconds by lifting the easing lever on the valve until water flows through the drain pipe.
- If expansion control valve is installed in the cold water pipe, repeat the above process for service.
- Ensure the drain pipe is not blocked.
- The pressure relief handle of TP valve should be pulled once every six months to remove the deposit calcium and confirm the device is not blocked. Its outlet water temperature may be high, so be careful to avoid scalding.
- The water may drip from the drainage outlet of the appliance and that the drainage hose must stay open to the atmosphere.
- In case of that drainage hose freezes in winter, which causes accident, please handle the drainage hose with insulation protection.

# 5. Trouble shooting

## Common Errors and Solutions

Table 1 Failure Code Table

Error Code	Error Name	Reason	Solution
<b>A12</b>	Low pressure switch protection	1. Low pressure switch is broken. 2. Refrigerant is too less. 3. There is non-condensable gas in the refrigerant circuit.	1. Replace low pressure switch. 2. Eliminate excess refrigerant. 3. Eliminate non-condensable gas.
<b>A13</b>	High pressure switch protection	1. High pressure switch is broken. 2. Refrigerant is too much. 3. There is non-condensable gas in the refrigerant circuit.	1. Replace high pressure switch. 2. Eliminate excess refrigerant. 3. Eliminate non-condensable gas.
<b>A14</b>	Flow switch error	1. There is no water flow 2. The water flow switch is faulty	1. Check water pump and pipeline. 2. Replace flow switch.
<b>A21</b>	Water tank Temperature sensor error	1. The connecting wire of sensor is open circuit or short circuit. 2. The sensor is broken.	1. Repair the wire. 2. Replace the sensor.
<b>A22</b>	Evaporator coil Temperature sensor error	1. The connecting wire of sensor is open circuit or short circuit. 2. The sensor is broken.	1. Repair the wire. 2. Replace the sensor.
<b>A23</b>	Discharge temperature sensor error	1. The connecting wire of sensor is open circuit or short circuit. 2. The sensor is broken.	1. Repair the wire. 2. Replace the sensor.
<b>A25</b>	Ambient Temperature sensor error	1. The connecting wire of sensor is open circuit or short circuit. 2. The sensor is broken.	1. Repair the wire. 2. Replace the sensor.
<b>A26</b>	Suction temperature sensor error	1. The connecting wire of sensor is open circuit or short circuit. 2. The sensor is broken.	1. Repair the wire. 2. Replace the sensor.
<b>A41</b>	Compressor overcurrent	1. The compressor is overload. 2. The compressor is damage. 3. The power supply is not stable.	1. Check water temperature. 2. Replace the compressor. 2. Fix the power supply.
<b>A51</b>	Communication error	Open or short circuit between circuit board and display board.	1. Fix the connection line. 2. Replace the connection line or display.
<b>A61</b>	High discharge temperature protection	1. Refrigerant is not enough. 2. There is non-condensable gas in the refrigerant system.	1. Add refrigerant to the circuit. 2. Eliminate non-condensable gas.

Table 2 Common Failures

Failure Description	Reason	Solution
The appliance does not work.	<ol style="list-style-type: none"> <li>1. Power failure.</li> <li>2. Power cable is loose.</li> <li>3. Control power fuse is broken.</li> </ol>	<ol style="list-style-type: none"> <li>1. Switch off power and check the power.</li> <li>2. Find out the problem and fix it.</li> <li>3. Replace the fuse.</li> </ol>
The appliance has low heating capacity.	<ol style="list-style-type: none"> <li>1. Refrigerant is insufficient.</li> <li>2. Bad water pipe insulation.</li> <li>3. Dry filter is blocked.</li> <li>4. Dirty air heat exchanger.</li> </ol>	<ol style="list-style-type: none"> <li>1. Check if there is leakage or recharge standard quantity of refrigerant.</li> <li>2. Do insulation again.</li> <li>3. Replace the dry filter.</li> <li>4. Clean air heat exchanger.</li> </ol>
The compressor does not work.	<ol style="list-style-type: none"> <li>1. Power supply or the controller is broken.</li> <li>2. The compressor's contactor fails.</li> <li>3. The wire is loose.</li> <li>4. The compressor's overheating protection works.</li> </ol>	<ol style="list-style-type: none"> <li>1. Find out the reason and solve it.</li> <li>2. Replace the contractor.</li> <li>3. Find out the loose point and fix it.</li> <li>4. Identify the reason of overheating and then turn on the appliance after repair.</li> </ol>
The compressor works noisily.	<ol style="list-style-type: none"> <li>1. Internal components are damaged.</li> <li>2. Frozen oil is not enough.</li> </ol>	<ol style="list-style-type: none"> <li>1. Replace the compressor.</li> <li>2. Add enough frozen oil.</li> </ol>
The fan does not work.	<ol style="list-style-type: none"> <li>1. The capacitor is broken.</li> <li>2. The screw is loose.</li> <li>3. The motor is broken.</li> </ol>	<ol style="list-style-type: none"> <li>1. Replace the capacitor.</li> <li>2. Tighten the screw.</li> <li>3. Replace the motor.</li> </ol>
The appliance does not heating, while the compressor is working.	<ol style="list-style-type: none"> <li>1. Refrigerant spreads out totally.</li> <li>2. The compressor is broken.</li> </ol>	<ol style="list-style-type: none"> <li>1. Check if there is leakage and fulfill the standard quantity of refrigerant.</li> <li>2. Replace the compressor.</li> </ol>
Discharge pressure is too high.	<ol style="list-style-type: none"> <li>1. Refrigerant is too much.</li> <li>2. Fluorine-way system contains non-condensable gas.</li> </ol>	<ol style="list-style-type: none"> <li>1. Expel excessive refrigerant.</li> <li>2. Exclude non-condensable gas.</li> </ol>
Suction pressure is too low.	<ol style="list-style-type: none"> <li>1. Dry filter is blocked.</li> <li>2. Refrigerant is too little.</li> </ol>	<ol style="list-style-type: none"> <li>1. Replace the dry filter.</li> <li>2. Check if there is leakage and fix it.</li> </ol>
<b>Non-Unit Failure</b>	<ol style="list-style-type: none"> <li>1) There is water flow out of the drainage outlet of the TP valve: When producing hot water, the cold water within the appliance is heated and expands, so there is water flow out of the drainage outlet of the drain valve, which is a normal case. However, if there is water extruding continuously, that means the TP valve loses efficacy. You should stop using the appliance and replace the TP valve as soon as possible.</li> </ol>	



**CAUTION**

This appliance must be installed, commissioned, and serviced by an authorized technician following the instructions and local legislations and regulations.

## 6. Warranty Policy

### Warranty Conditions

1. The SolarBuild heat pump water heater system must be installed in accordance with the installation instructions supplied with the product and all relevant statutory/local requirements of the state/province/municipality in which the water heater is installed.
2. SolarBuild heat pump water heater must be handled, installed, operated and maintained in accordance with the manual.
3. Where a failed component or SolarBuild heat pump water heater is replaced under warranty, the balance of the original warranty period will remain effective. The replaced part or SolarBuild heat pump water heater system does not carry a new warranty.
4. Where the SolarBuild heat pump water heater system is installed in a position that does not allow safe, ready access, the cost of accessing the site safely, including the cost of additional materials handling and/or safety equipment, shall be the owner's responsibility.
5. The warranty only applies to the SolarBuild heat pump water heater system and original or genuine component replacement parts and therefore does not cover any plumbing or electrical parts supplied by the installer and not integral part of SolarBuild heat pump water heater system.
6. This warranty is for parts only. Any and all labour costs associated with diagnosis, removal of the faulty part and installation of replacement parts will be solely the owner's responsibility.

### Warranty Exclusions

Repair and replacement work will be carried out as set out in the SolarBuild heat pump water heater system warranty. However, the following exclusions may void the warranty and may incur additional service charges and/or cost of parts:

1. Accidental damage to SolarBuild heat pump water heater or any component, including: Acts of God, failure due to misuse, incorrect installation, attempts to repair the water heater other than by a SolarBuild accredited service agent.
2. Where it is found there is nothing wrong with the SolarBuild heat pump water heater system, where the complaint is related to excessive discharge from the temperature and/or the pressure relief valve due to high water pressure; where there is no flow of hot water due to faulty plumbing; where water leaked are related to plumbing and not the SolarBuild heat pump water heater system or its components; where there is a failure of electricity or water supplies; where the supply of electricity or water does not comply with relevant codes or acts.
3. Where the SolarBuild heat pump water heater system or its component has failed directly or indirectly as a result of excessive water pressure.
4. Overflow vent drain has not been installed or blocked or corroded.
5. Where the SolarBuild heat pump water heater system has rusted as a result of a corrosive atmosphere.
6. Where the unit fails to operate or fails as a result of ice formation in the piping to or from the SolarBuild heat pump water heater system.
7. Where SolarBuild heat pump water heater system is located in a position that does not comply with the SolarBuild heat pump water heater system installation instructions or relevant statutory requirements, causing the need for major dismantling or removal of cupboards, doors or walls or use of special equipment to bring the SolarBuild heat pump water heater system to floor or ground level or to a serviceable position.

8. Repair and/or replacement of the SolarBuild heat pump water heater system due to scale formation above 200ppm (water hardness) in the waterways or the effects of either corrosive water or water with a high chloride or low pH level when the water heater has been connected to a scaling or corrosive water supply or a water supply with a high chloride or low pH level as outline in the manual, or water quality not follow the limits specified in Section 2.4 in the manual.

9. Warranty service is provided to the original owner of the equipment only. Subject to any statutory provisions to the contrary, this warranty excludes any and all claims for damage to furniture, carpets, walls, foundations or any other consequential loss and/or pipe work of metal, plastic or other material caused by water temperature, poor workmanship or other modes failure.

### Warranty Period

Subject to the Warranty Conditions and Exclusions stated above, your SolarBuild heat pump water heater system is warranted in a residential application as follows:

<b>Component</b>	<b>Warranty Period (Parts Only)</b>	<b>Warranty Period (Parts and Labour)</b>
Glass Lined Tank	6 years	1 year
Refrigeration	5 years	1 year
Electrical (controller and sensor leads)	5 years	1 year
Sacrificial Anode & PTR valve	1 year	1 year
Consumable Items	1 year	1 year

### Claims procedure

Follow the below steps to make a claim under this warranty:

1. Contact SolarBuild on 1300 493 699 during business hours or at [info@solarbuild.com.au](mailto:info@solarbuild.com.au).
2. Provide proof of purchase of the goods; and
3. Provide complete details about the issues you are experiencing with the goods.